

## Stairs lighting controller MEMC - 2016

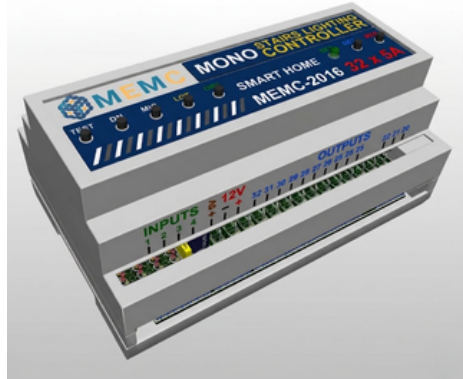

The **STX-1797** controller serves for a dynamic control of the lighting of stairs. The lighting is switched on for consecutive steps, upwards or downwards, depending on the desired direction. **The controller can control up to 32 stairs.**

The controller has 3 different modes of light animation programs (upwards): **WAVE** – stairs light up one after another, **CASCADE** – the light „jumps” fast from top to bottom, lighting up the steps, **ELEVATOR** – three steps are lighted slowly, towards the top of the staircase. Downwards, the direction of the animation is changed suitably. You can permanently select one of the programs or set the options to cyclically change programs.

The controller has four inputs which permits it to react to two or three detectors. This for instance makes it possible to serve a mezzanine with an entrance to the staircase. Input No. 4 allows you to turn the staircase lighting permanently on.

Depending on the way the parameters of the controller are set, the lighting of the stairs can fade out totally or to a predetermined minimum value (making it possible to faintly light up the stairs, or to walk them easily in the dark — without turning on a full light — especially important for children!). When you press the top button, the stairs are lighted from top to bottom or turned off in the same direction.

If another person steps on the stairs, the controller switches on a full illumination of stairs and after some time fades them out smoothly.

The controller is adapted to control **MONO LED** strips mounted in stair steps or **LED** points (spots) built into the wall above the steps. The **LED** strip controller can light up each step smoothly, which gives a nice visual effect.

Lights can be turned on by directly pressing a button on the wall, which is connected to the controller, or by using an additional sensor (infrared, motion, pressure, etc.), which detects when a person steps on the stairs.

The controller can be used for up to **32 steps**. It can also control lighting of one or two handrails. If there is no handrail, the controller can serve to turn on ceiling lights (12V).

The controller also can be used for a staircase with an entrance to a mezzanine. In such a case an additional sensor or button is necessary. You can choose in this case, brightening the whole staircase or animation (**WAVE**) from the mezzanine down and up.

All the parameters of the controller can be set by the user. In the original (factory) settings, the controller is ready for lighting up 20 steps, without lighting up the railing. It can be set up for a different number of steps, from **5 to 32**. It is also possible to light up one or two rails. Other parameters can also be changed. These include: turning the lighting of the stairs on or off in the dark, the time steps are lit up, the time interval between the lightening up of successive steps (this influences the speed of lightening of the whole staircase), or the time after which the steps will be faded out. If motion detectors are used, „dead” time can be set after receiving a signal from a sensor, or if there is no response to

one or both of the sensors, until the end of the animation program, to prevent re-lighting the stairs while going down. It is also possible to preset a longer time to start up the controller, so that it does not react to transient states after power is turned on. At any time, factory settings can be restored.

## Specifications

- Maximum number of illuminated stairs — 23
- Number of illuminated handrails — 2
- Supply voltage — 12V
- Dimensions: length — 11cm, width — 9cm, height — 7 cm
- Mounting on T-35 rail — the width of 6 modules.
- Output capacity — up to 5A per one output
- Running — by short-to-ground (negative power supply)

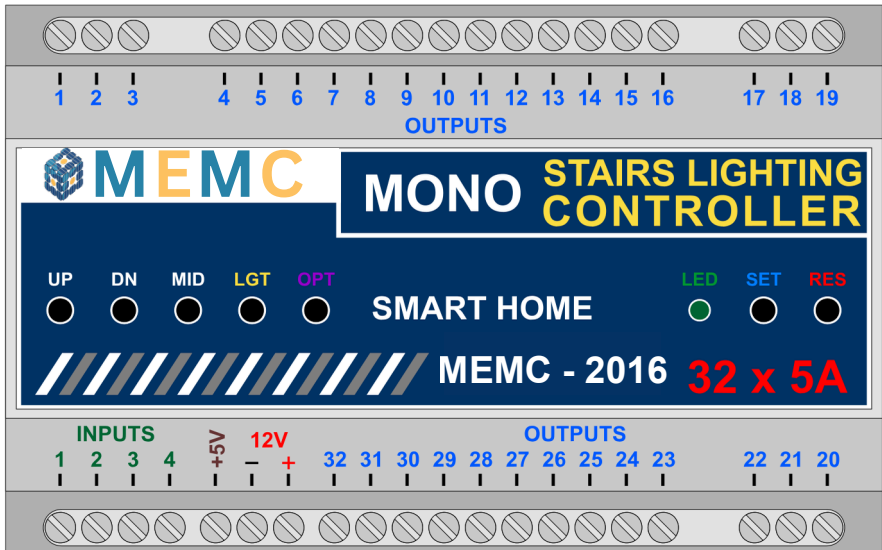

## Functions buttons and control LED

Description of buttons on the body:

- UP** – button starts the animation towards the top
- DN** – button starts the animation towards the bottom
- MID** – button starts the animation from the platform
- LGT** – button switch on/off continuous light
- OPT** – button for additional options (not used)
- LED** – LED indicator
- SET** – setup button
- RES** – reset button

## Installation

---

The controller should be installed by someone with skills in the field of electrical engineering, preferably a certified specialist. The controller must be installed with the power off!

Power supply for controller and LEDs should be stabilized with an adequate current capacity depending on the amount and length of the used LED strips or 12V LED light. Do not use a power supply (type 12) for halogens — the controller will be damaged immediately! The controller is designed for a voltage of 12 V DC (stabilized). Maximum current per output is 5 A. Do not exceed this value.

The first step is to connect the lights (LED strips or spots) to the controller. When you connect the 12V power supply, the stairs lighting should turn on with minimum brightness (so-called stairs illumination effect). When the **TOP** button on the controller body is pressed, the lighting up of the steps one by one should begin. If this does not happen, the way the LED lighting is connected should be checked carefully. Similarly, the animation after the button **BOT** is pressed should be checked – in this case, the stairs lighting should take place downwards.

It is recommended to adjust the sensor response to movements without connecting them to the inputs of the controller. The sensor pulse time (TIME) must first be set to extreme minimum and it should not be changed during adjustment. The sensitivity (range) also should be set at the minimum - but this parameter can be adjusted. In some sensors, the support function should be disabled or properly adjusted (triggered). Only after the proper operation is obtained of the sensors, they can be connected to the controller.

Only after obtaining the proper light animation, you can begin to connect the motion sensor.

The last step is time intervals adjustment. The best way is to do it after a few days of using the stairs in order to determine as accurately as possible the necessary changes. We recommend you do not adjust the parameters without a specific reason. For greater safety, changing the parameters are blocked by the factory (see the chapter on adjusting the controller)

## LED Lighting

STX-1795 can control the backlight done by LED strips and 12V LED lights (not 230V!). Strips are usually mounted under the steps, and the LED lights by the side of the steps. Connections between lighting elements are shown on the following illustrations.

### LED strips

A popular way for backlighting stairs is to use LED strips. In the case of the STX-1795 controller, one-color strips (mono) should be used. Any color can be chosen. To control colored bands (RGB) there is the dedicated STX-1793 controller. The standard supply voltage is 12V. The controller can also be connected to 24 V LED strips, but because of the controller electronics, the voltage should not be exceeded.

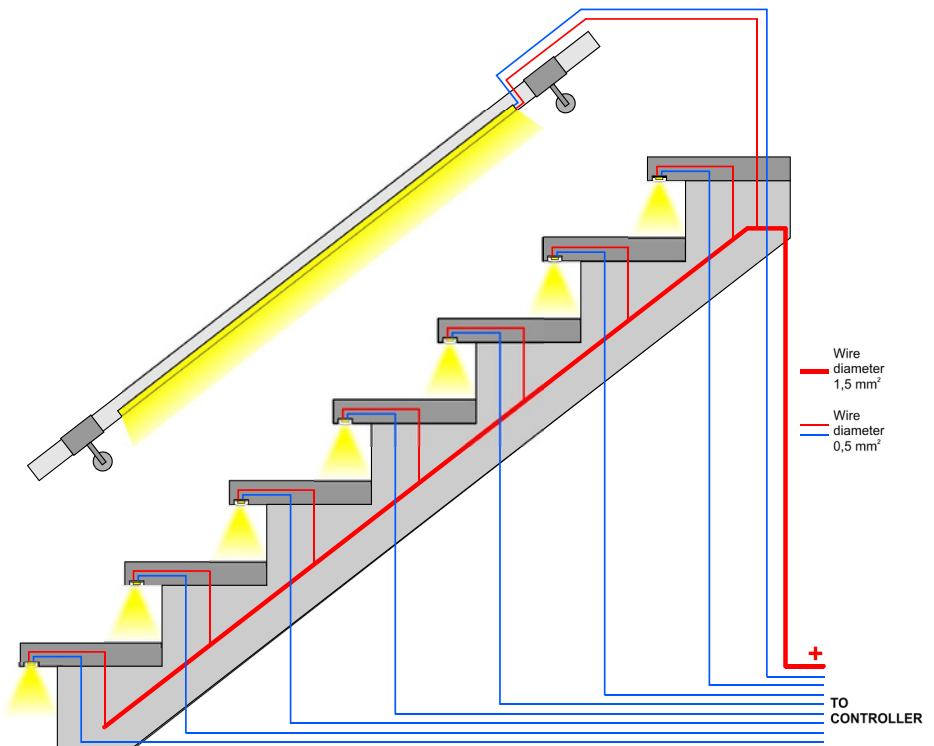

Instalacja elektryczna stopni schodów - taśmy LED

Electrical installation LED strips

LED strips are usually placed under the steps. Points (+) should be connected together and by a single 1.5 mm<sup>2</sup> wire fed to the controller. Points (-) of LED strips should be connected by separate wires of 0.5 mm<sup>2</sup> to the controller, as shown above.

You can also use one pair of wires 0.5 mm<sup>2</sup> for each LED strip to the controller separately. Both solutions are equivalent.

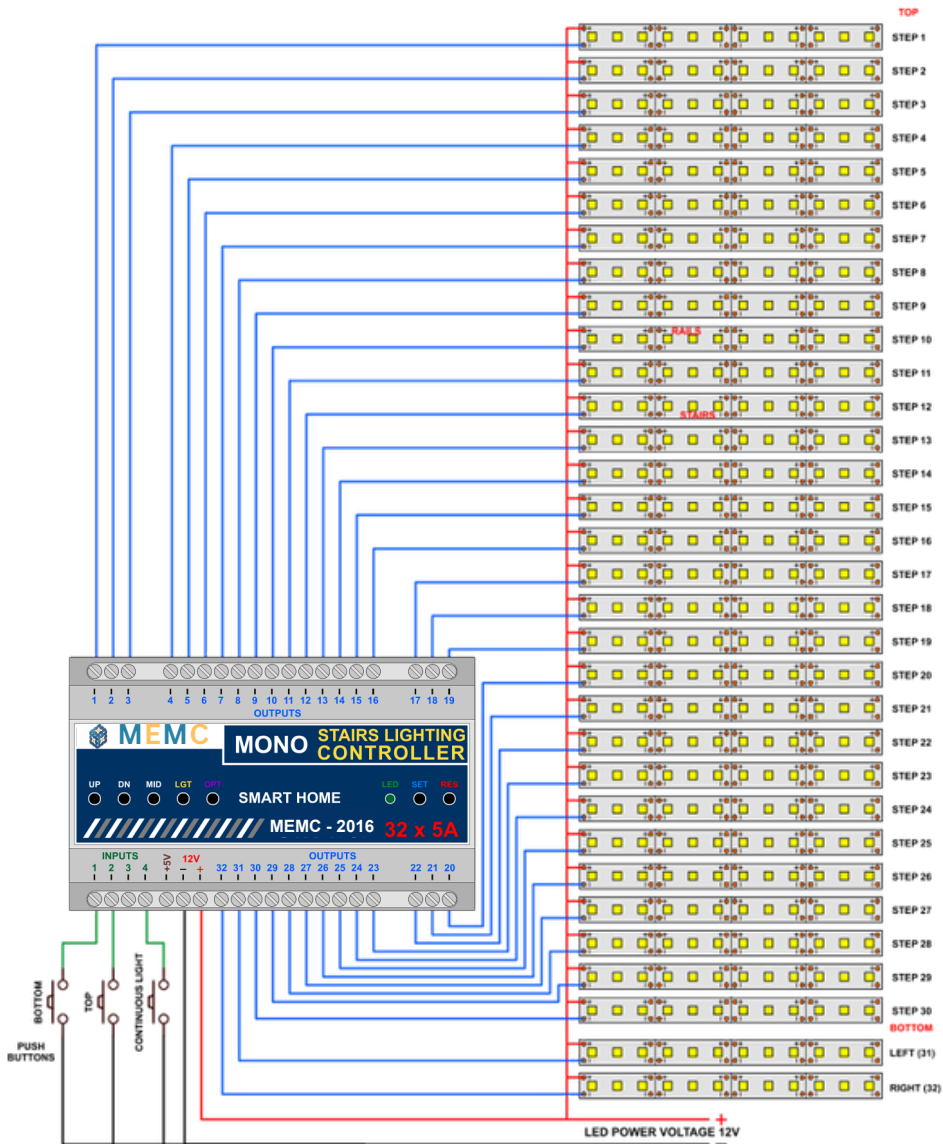

LED strips connected to the controller

The diagram above shows the connection of the controller to the staircase consisting of 30 steps and two handrails. Output 1 is connected to the first ( lowest) level, output 2 to the second higher, etc.

The output 32 is connected, looking from the bottom of the stairs, to the right handrail (running up), and the output 31 to the left handrail (running down) . All the points (+) of LED strips should be connected with each other and the + value, points (-) should be connected to the outputs of the controller.

## LED lights (spots)

Another way to backlight the stairs is to place a small LED light (spot) on the wall above each step. Lights must be adjusted to a voltage of 12V. We recommend the use of dimmable lights — then you will be able to backlight the stairs, and smoothly to illuminate each step.

If possible, place the lights above each step — this ensures a smooth animation effect. If there is a platform - you can add 1-3 lights to enhance the effect and treat it as additional step.

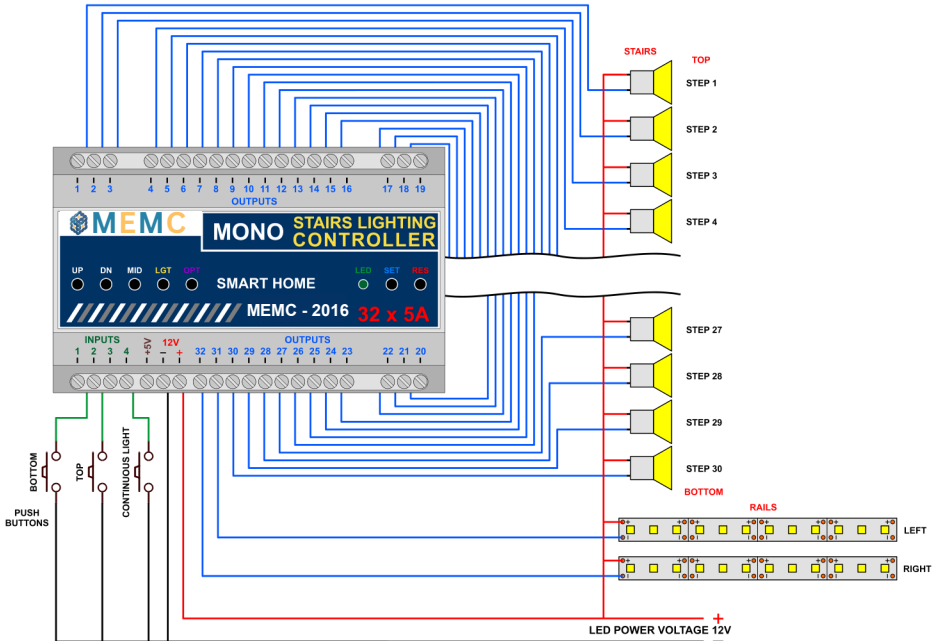

12V spots connected to the controller

The diagram above shows the connection of the controller to a staircase with 19 steps and two handrails. Output 1 is connected to the first spot light on the lowest level, output 2 to the second one, etc. Output 19 is connected to the last (19) spot. Output 25 is connected, looking from the bottom of the stairs, to the right handrail (running up), and output 24 to the left one (running down). Lamps generally have no polarity, so you should just follow the rule that the lights should be connected with each other and with the plus value, and the second pole of each lamp must be connected to the corresponding controller output.

If the staircase is smaller and there are no illuminated handrails, you can use exit No. 25 for example for ceiling lighting above the stairs (of course, if you have one). However, LED elements with 12V power must be used. Do not connect lighting powered by 230V!

The next diagram shows a solution where output 25 is connected to three 12V LED lights placed on the ceiling above the stairs. The controller will turn them on with the first step, and turn them off about 2 seconds after the lighting of the last step turns off. Of course, you can use any other light source with the voltage of 12V, depending on the design of the stairs, instead of the ceiling lamps.

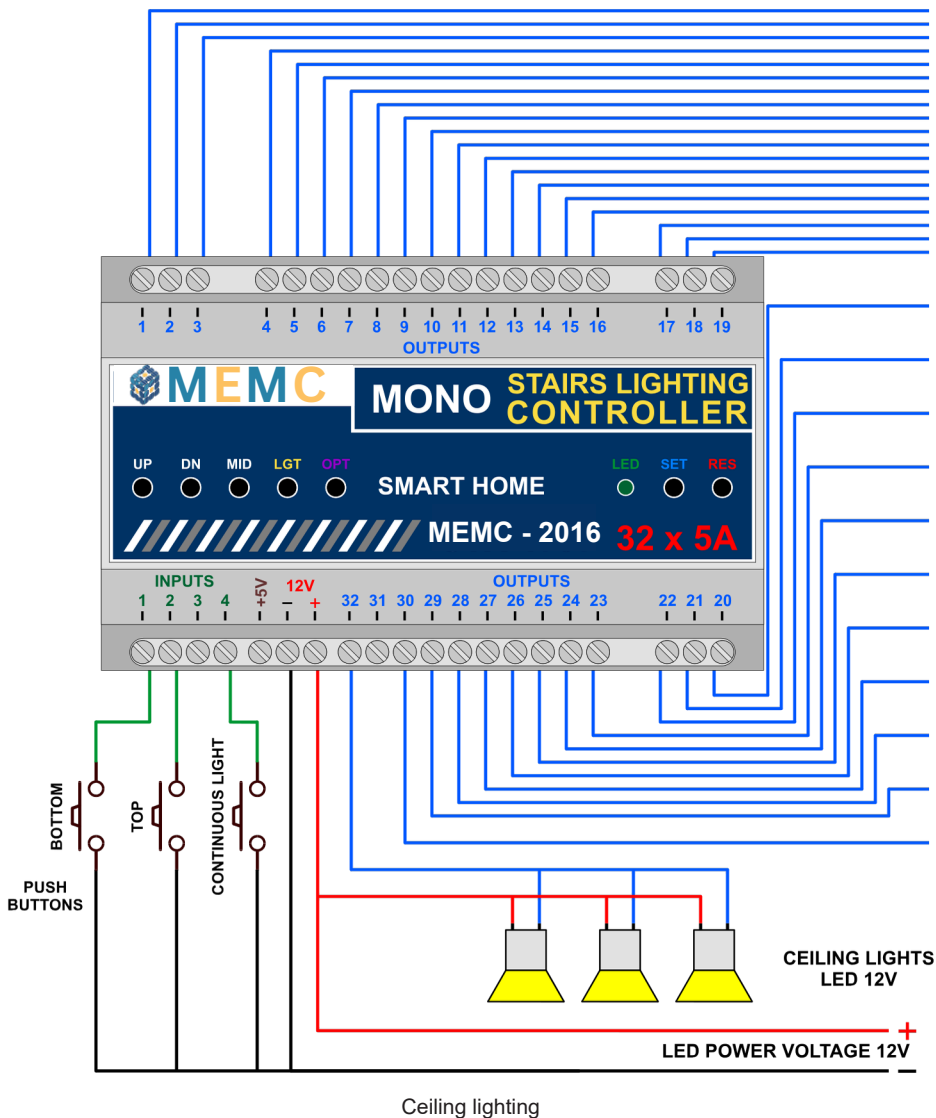

Ceiling lighting

When designing the connections between the controller and LED points, the appropriate type of wiring should be selected, according to the current flowing in the circuit. The (+) supply line for 12V LED strips or LED lights should have a much larger cross-section than the cables between the controller and individual LED strips.

Installation must be carried out very carefully and securely to avoid loosening of wires or short circuits between them. LED strip wires should be soldered. We do not recommend using special sockets and plugs, because after a while, due to the movements of the stairs, they become loose and may lose contact.

## Control

---

Controller inputs function on a short to ground basis.. Any mechanical button (not a switch) will activate the controller after a short press. One end of the button should be connected to the controller input, and the other should be grounded (-) of 12V). All the above diagrams show this solution.

You can also run the controller with other elements or devices, including motion sensors. Motion sensors can be found in two versions: a voltage of 230V voltage and a voltage of 5 or 12V. Do not connect the sensor directly to the input of the controller, because, especially in the case of 230V sensors, it will cause (at best) incorrect performance of the controller, and at worst the controller can be completely damaged.

Before mounting the sensors, set their parameters. The most important is the length of the impulse (the time for the sensor to start), which should be set to a minimum and should not exceed 15 seconds (preferable time about 1-5 seconds — this should be checked before purchase). The second parameter which can be set on the sensor is the sensitivity and range of the sensor. This parameter should be set experimentally in order to enable a steady connection at the proper time.

In some sensors you can choose between various modes of operation. The triggering mode should be turned off, because in this mode the sensor provides the impulse continuously when someone is within its range - and the impulse becomes too long in respect to the requirements of the controller.

Sensors operating at 230V network require the use of relays to separate the 230V circuit from the controller inputs. Low voltage sensors will almost certainly need a special adapter, matching the sensor signal to requirements of the controller. The following diagrams and descriptions explain how to connect the most common types of sensors. If you need to use a different type of sensor, please contact the manufacturer to establish how to connect the sensor.

We recommend that buttons (such as door bell ones) are installed on the top and bottom of the stairs, besides motion sensors..

## Motion sensors with a voltage of 230 V

---



Motion sensor for 110-230V - CRN 5491

A typical motion sensor (230V) is a standard size module and is connected to the installation box. It has regulatory elements (time, sensitivity, etc.) and usually three contacts for wires. Two are plugged into a 230V network, and the third wire is used to power the receiver (the lamp) and is marked with an appropriate symbol. Before installing the sensor, carefully read the instructions.

Some motion sensors have a built-in additional twilight sensor. Depending on the sensitivity settings it can be inactive in strong light. Thus, illumination of the stairs does not turn on during the day. However, this may cause problems - if it rains, the twilight sensor will lighten the stairs. By adjusting the sensitivity, you can try to prevent this. We can recommend our 230V sensor CRN-5491, modified to work with our controller..

The next diagram is one of a typical motion sensor (230V) connected to the controller. Relays must be used! Relay coil voltage must be set at 230V, because this voltage is supplied from the motion sensor. Connect input 1 or 2 and (-) of 12V to the contacts of the relay NO (normally open) and CO (common).. We recommend the assembly to be done very carefully. If the connections are made erroneously, the controller will be damaged.

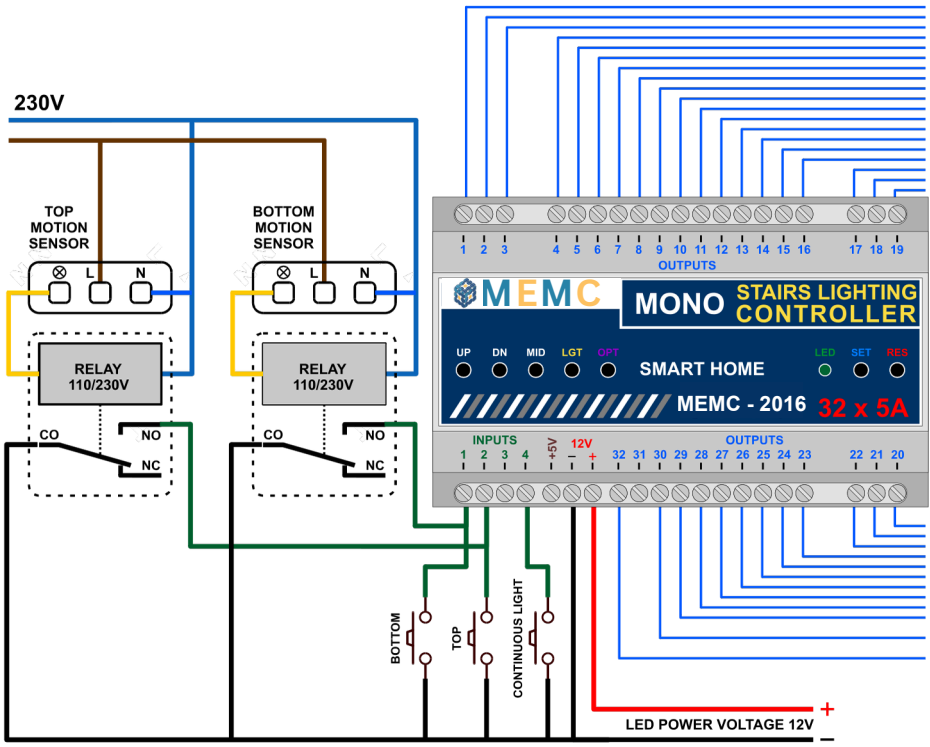

Installation diagram: 110-230V motion sensors connected to the controller



Set of two relays STP-4811

The relays used to separate 230V circuit from the controller may be of any type. We recommend the relays to be mounted on T-35 bus, the same as the controller. Their use helps with the installation.

Photo to the left shows our product STP-4811 — a set of two relays in a single-rail case T-35. This set makes it possible to separate 230 V voltage coming simultaneously from two motion sensors.

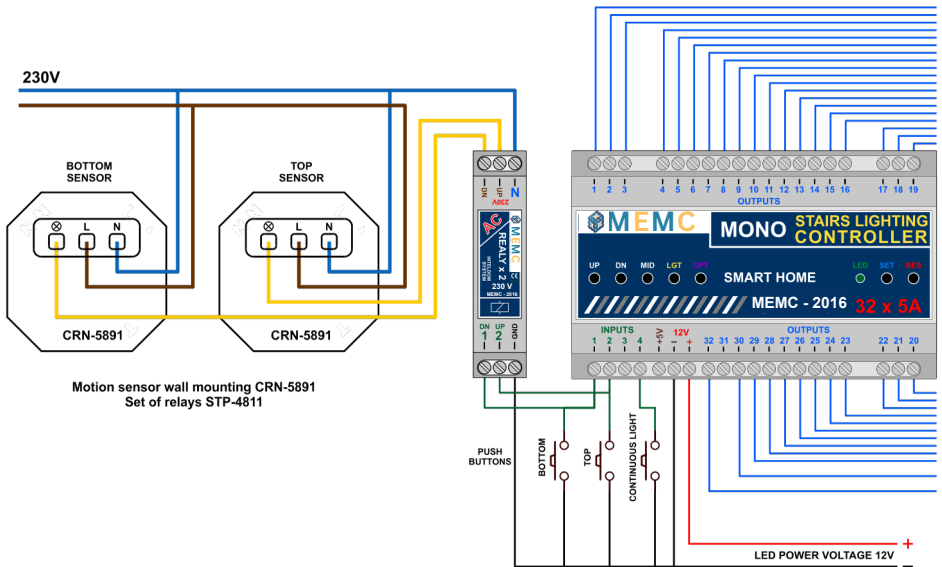

Assembly diagram of motion sensors CRN-5891 connected to the controller by a set of relays STP-4811

NOTE: The knob „Time” in the sensors must be set to the minimum position!

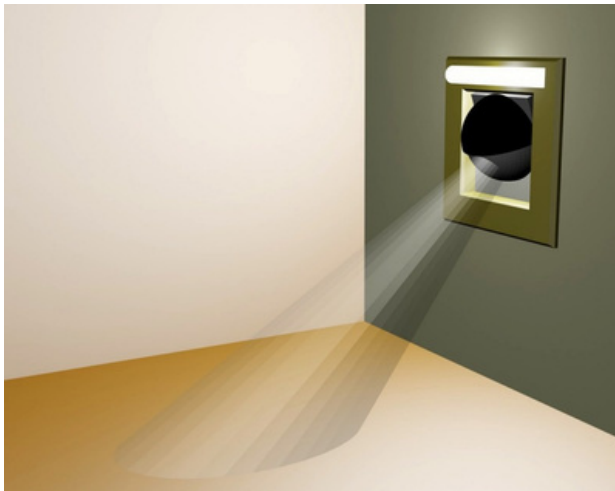

The motion sensor mounted on the wall

Installation of motion sensors in order to work properly is extremely difficult. The visualization presented here may be helpful.

We recommend the sensor to be tilted down, so it „sees” only a portion of the first step. The top of the Fresnel lens should be covered with an opaque material. If the motion sensor does not have a built-in light sensor, at least a small, steady source of light over the sensor should be added to light up the field observed by the sensor.

## Motion sensors for 5-12V voltage

---

Low voltage sensors differ in dimensions, capabilities and working principle. We will briefly discuss all of them. For detailed information, please refer to the instructions for each type of sensor.

### Subminiature motion sensor 5V CRN-5480

---

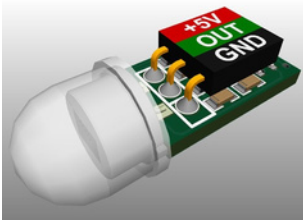

The **SRN-5480** sensor has the smallest dimensions of all sensors. For use in particularly difficult places, where it would be impossible to mount a different, larger sensor. Dimensions: 26x10x10 mm. The sensor does not have any adjustment elements. The field of view of the sensor and its sensitivity can be limited by sending a bowl from the inside (it is removable). It is powered from the special + 5V output of the controller. It has a diode signaling the sensor pulse.

### Miniature motion sensor 12V CRN-5486

---

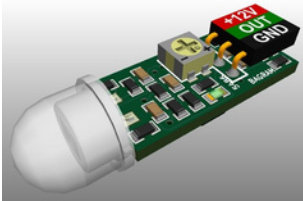

The **CRN-5486** sensor is characterized by small dimensions and full functionality. Dimensions: 36x12x10 mm. The sensor has a wide range of sensitivity adjustment, as well as a removable bowl that can be screened to reduce the field of view. It is equipped with a diode signaling the impulse of the sensor. It can be powered from the same voltage (12V) as LEDs.

### Standard motion sensor 12V CRN-5481

---

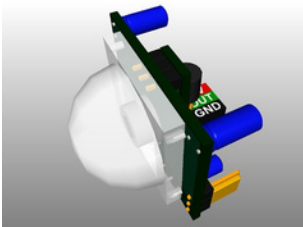

The **CRN-5481** sensor fits freely into a 60 mm mounting box. Dimensions: 32x24x18 mm. The sensor has a wide range of sensitivity adjustment, as well as a removable large bowl that can be accurately outlined to reduce the field of view. It can be powered from the same voltage (12V) as LEDs.

### Twilight motion sensor 12V CRN-5484

---

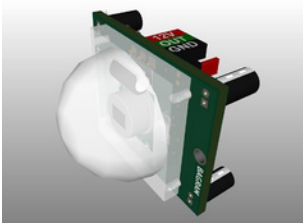

A special feature of the **CRN-5484** sensor is the twilight sensor installed. It blocks the work of the sensor if the light level exceeds the set value. The sensor fits freely into a 60 mm mounting box. Dimensions: 32x24x18 mm. The sensor has a wide range of sensitivity adjustment, as well as a removable large bowl that can be accurately outlined to reduce the field of view. It can be powered from the same voltage (12V) as LEDs. It has a diode signaling the sensor pulse.

## Czujnik ultradźwiękowy 5V CRN-5462

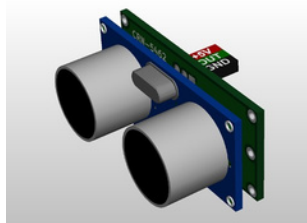

The **CRN-5462** ultrasonic motion detector has a precisely adjustable field of view range from 1 cm to 250 cm. The field of view can have a selected depth and distance from the sensor in the range of 1 cm to 250 cm. Dimensions: 46x20x20 mm. The sensor fits freely into a 60 mm mounting box. It can be supplied with the same voltage as the LED diodes. It has a diode signaling the sensor pulse.

## Installation of sensors 5 and 12V

Each low voltage sensor can be directly connected to the controller input. It is important that the sensor and the controller itself are connected in the correct way. Be careful not to connect the 5V sensors to the 12V LED power supply. 5V sensors must be powered from a special + 5V controller output.

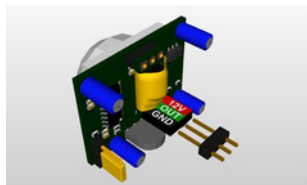

On the back of the sensor is a connector for connecting wires leading to the controller. To facilitate assembly, to each sensor is added the connector to soldering wires. You should keep the correct order of wires according to the description on the sensor connector.

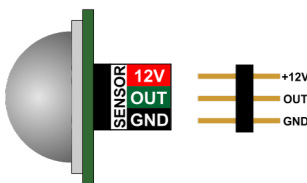

It is recommended to use colored wires with a possibly small cross-section, eg a telephone cable harness. Please note that any mistake in connecting wires, especially power supplies, can damage the sensor or controller. To facilitate assembly, to each sensor is added the connector to soldering

The sensor's angle of view can be adjusted by gluing the sensor's bowl (removed) from the inside with a white insulating tape so that it does not see people passing by. For the ultrasonic sensor, select and set the work zone.

The sensors can be mounted in a skirtingboard or bound. It's best to use the so-called frame with end cap. A hole should be drilled in the cap with the diameter of the sensor bowl or with the diameter of the emitters.

Before installing the sensors, their operating time and sensitivity must be set to minimum. In the case of sensors having a jumper for selecting the mode of operation with or without support (triggering), select the „non-repeatable trigger” position.

Two sets of sensors prepared in this way should be installed in a suitable place near to the first and last stage.

The diagram on the next page shows exactly how the whole set is built with the use of 12V motion sensors.

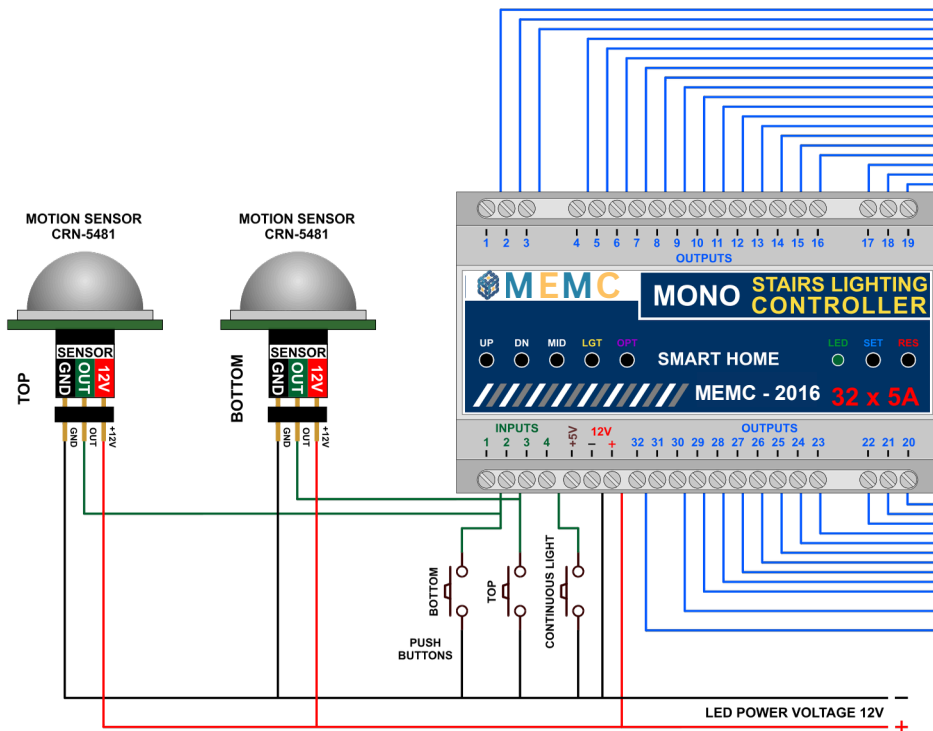

Installation diagram: 12V motion sensors connected to the controller

The controller can handle additional input located on the mezzanine. In such a case, an additional motion sensor (or an additional push button) should be placed so as to detect the entrance a person to the staircase mezzanine, but so it does not react to people walking up the stairs.

After detecting a person entering the stairs to the mezzanine, the controller will immediately start the lighting of the whole staircase and turn it off after approx. 20 seconds. The diagram on the neighboring side shows such a solution.

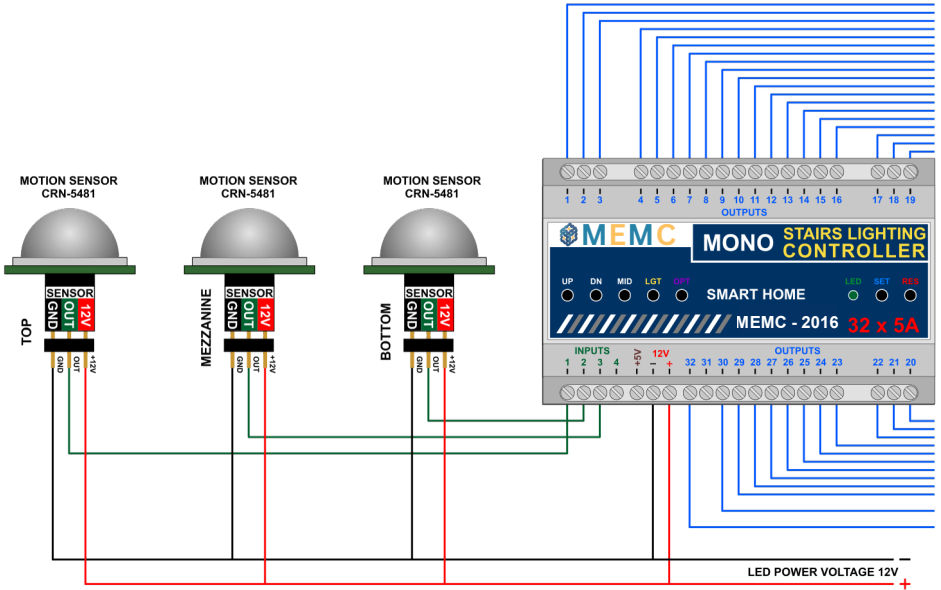

Mezzanine case.  
 Installation diagram shows connecting three motion sensors 12V to the controller.  
 An optional button is not shown.

## Adjusting the controller

Setting the parameters should be performed only when strictly necessary, after reading the following description carefully.

To start the parameter setting mode, press and hold the **SET** button until the green **LED** fades out. Release the button to go on to the controller parameter setting mode. A few seconds flickering of the **LED** (and first step) corresponds to each parameter. You can set or change 12 parameters, and therefore there will be twelve consecutive flickers of the **LED**. In order to facilitate counting them, a marker is inserted after every five flickers – a two second **LED** constant light. To select a specific parameter to be changed, you should count each flicker and then, after a suitable number of flickers, press the **SET** button. If you do not want to change a parameter, skip the flickering without pressing the button. If at the parameter setting mode the **SET** button is not pressed, none of the parameters will change.

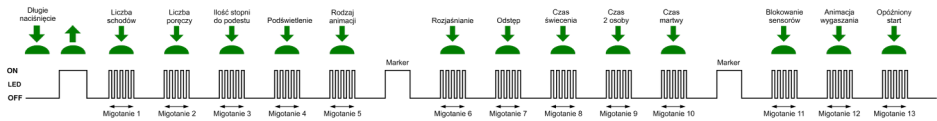

Adjusting controller parameters diagram

The principle of setting the parameters is as follows: setting each parameter is indicated by a rapid flickering of the green **LED** (and first step). If during this flickering the **SET** button is pressed and held, then, depending on the parameter, you will see from one to several dozens of slow **LED** pulses. Setting the parameter takes place after a release of the button after the desired number of pulses or just after the end of the flickering. During the flickering, if the **SETUP** button is not pressed, after a short time of the **LED** fading out, flickering of the next parameter will appear and so on until the end of the setting mode. If the given flicker is omitted, the corresponding parameter will not be changed. This allows you to set only one parameter, without any of the others. Notice: if the **SET** button is pressed during the flickering and released immediately after it, but before the first pulse, the parameter will return to the factory setting.

After setting the selected parameter, the controller immediately returns to a stand-by state, waiting for a signal from pulse sensors or push buttons. There are no flickers for other parameters. To set another parameter, use of the **SET** button again.

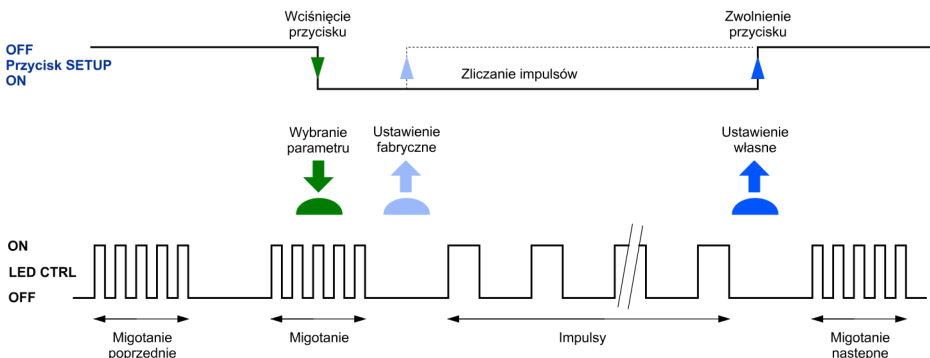

Setting a single parameter

## Description of parameters

---

### Flickering 1 – Count of stairs.

---

The controller is factory-set for 15 steps. This can be changed with this parameter. The range is from 5 to 23 steps. To change the number of steps, press and hold the **SET** button during the first flickering. You should release the button after the right number of flicks. Eg., to set 18 steps, release the button after 18th flick.

### Flickering 2 – Count of rails.

---

The controller is factory-disabled for lighting the railing. You can turn on one or two rails. Note: two rails should be set only if in the entire staircase there are handrails on both sides. In other cases, such as one handrail divided into two sections, set the operation to one handrail! Releasing the button after the first slow pulse sets the lighting for one rail, and letting go after the second pulse – sets the lighting for two rails. Releasing the button after the end of flickering and before the first pulse switches off the backlight railing.

### Flickering 3 – Count of stairs to a mezzanine.

---

The controller also can be used for a staircase with an entrance to a mezzanine. This case supports the third detector (or button) connected to the input No. 3. The controller is factory-set to no animation at the entrance to the mezzanine - turn on the whole staircase. However, you can start the animation consisting of successive lighting of stairs up and down from the mezzanine. You will need to set in this option, which is the number of stairs from the bottom to the mezzanine. To set the number of steps, press and hold the **SET** button during the third flickering. You should release the button after the right number of flicks. Eg., to set 8 steps, release the button after 8th flick. To re-enable lighting up stairs upon entering mezzanine you must let go of the button immediately after the third flickering.

### Flickering 4 – Staircase backlight.

---

Steps backlighting is used to gently brighten the steps so they are easily visible, which gives a pleasant impression. There is no possibility of adjusting the backlight brightness. The backlight does not work with lamps without a dimming function (dimnable); in such a case it should be turned off. For this parameter (backlight on), releasing the button just after the flickering ends turns the backlight off, and releasing after the first pulse – turns it on.

### Flickering 5 – Animation type.

---

The controller has 3 different light animation programs (for upward direction): **WAVE** – stairs light up one after another, **CASCADE** – the light „jumps” fast from top to bottom, lighting up the steps, **ELEVATOR** – three lighted steps slowly „move” to the top of the staircase. When descending, the direction of the animation changes suitably. In the factory, the animation cycle is preset in the following way: first **WAVE**, then **CASCADE** and finally **ELEVATOR**, and then the sequence is repeated. Releasing the button after the first pulse turns the program 1 (Wave), the second pulse turns on program 2 (Cascade), and releasing the button after the third pulse switches permanently to program No. 3 (Elevator). To return to the cycle animation function, the button should be let go immediately after the end of the flickering.

## **Marker – Fixed light – 2 sec.**

---

### **Flickering 6 – Lighting of the steps.**

---

You can set the time of a slow lighting of the steps. This gives an effect which is more than pleasing than turning on a sharp light at full power. The factory setting is 10, which corresponds to 0.5 second time of single step illumination (a total of 10 seconds for 20 steps). Releasing the button after the end of the flickering sets the time to the default value (approx. 0.5 sec. – 10 units). However, if the button is held on, you can set a different, shorter or longer period of time for the illumination a single step. The number of pulsees is proportional to the time of illumination. Just hold the button for the appropriate number of pulsees (default setting of 10).

### **Flickering 7 – Time interval between lighting consecutive steps.**

---

Releasing the button after the end of the flickering sets the time at the minimum, so that the speed of the staircase lighting depends on the time of steps illumination. However, if the illumination time (parameter 4) is set at a low or zero value (for example, when lamp lights are used), set the value of the experimental time interval so that the steps will light up at the right speed. Number of pulsees is proportional to the time interval and is approximately 0.5 seconds per unit (impulse). This parameter is factory-set to 0 (minimum value), which makes the next step is lightened immediately after the previous one.

### **Flickering 8 – Time between illuminating and fading out the staircase.**

---

It is a time in which, after switching steps such as one by one, they light up continuously at all levels, before the start of their fading out. Factory value is set to 10 seconds, which is equal to 10 impulses (1 impulse = 1 second).

### **Flickering 9 – Time of illumination for a second person.**

---

If another person enters the staircase, the illumination of all steps will be turned on. It is measured from zero at each entry of another person; the light will turn off after a set time measured from the entry of the last person. This time is pre-set to 20 seconds, which equates to 20 impulses (1 impulse = 1 second).

### **Flickering 10 – Controller blockade time.**

---

If the sensor detects more than one impulse, for example, due to the movement of other people on the stairs, the controller can react by turning on the lights over all of the stairs, just like during the entrance of another person. To avoid this, you can set the so-called blockade time counted from the end of the first impulse, during which the controller will not respond to further impulses. Blockade time is pre-set for 2 seconds, which corresponds to 2 impulses (1 impulse = 1 second).

## **Marker – Fixed light – 2 sec.**

---

## **Flickering 11 – Sensors lock.**

---

This is an important parameter when installing motion sensors. In some cases, motion sensors cannot be placed in an ideal direction. This happens when a person starts going down the stairs, and turns on all the lights, as if another person walked the stairs. This can be prevented by blocking the sensors in two ways. When you release the button after the first impulse, the sensor opposite to the one that started the animation is blocked. When released after the second impulse, both sensors are blocked. The lock lasts for the duration of the animation to the end of lighting time of the stairs or turning on the backlight. From that point on the two sensors are again active and animation can be run in either directions. You can disable the lock by releasing the button immediately after the end of the flickering. In a new controller, the lock is turned off.

## **Flickering 12 – Fade out animation.**

---

If another person comes up the staircase, all the lights light up. They can be turned off by a smooth, slow fade or animation of the steps. Releasing the button immediately after the flickering sets the first option, and releasing after one impulse - the second one.

## **Flickering 13 – Delayed start of the controller.**

---

Some motion sensors, after the power is turned on, transmit a long impulse, often lasting dozens of seconds.. It can cause an incorrect operation of the controller (eg a constant light). In this case, you can set a delayed start of the controller — about 1 minute. At that time, after powering of the whole system, the controller does not respond to the buttons or sensors. This is indicated by the blinking of all steps. Normally, the delayed start function is on. Releasing the button immediately after flickering turns delayed start off, and after one impulse – turns it on.

## **Reset of the controller.**

---

If the user incorrectly changed the parameters and it had an impact on the controller operation, you can easily restore the factory settings of the parameters. Use the **RES** (Reset) button on the top of the controller. As it is recessed into the case, to press it use a proper stick, for example a match.

To reset the controller, press and hold the **RES** button. After a while, the **LED** will flash. The button must be pressed continuously during all the flashing time. After the **LED** stops to flash and turns off, you can release the button. Reset is confirmed by five short flashes of the **LED**.

At this point, the parameters are reset to their default settings and the controller will work normally in standby mode, waiting for a signal from the button or sensor.

## **Turn on stairs on permanently.**

---

To turn the light of the stairs on permanently, press a push-button connected to the Input No. 4 To turn off the permanent light, press again the same push-button. The controller then switches to normal functioning.